

INSTALLATION AND OPERATION MANUAL

MV1 — PROGRAMMABLE PULSE FREQUENCY DIVIDER

The MV1 Programmable Pulse Frequency Divider provides a single output pulse following the detection of a specified number of input pulses. The number of input pulses is programmable, along with other features. It is designed for use in systems which incorporate either mechanical or electronic sensors.

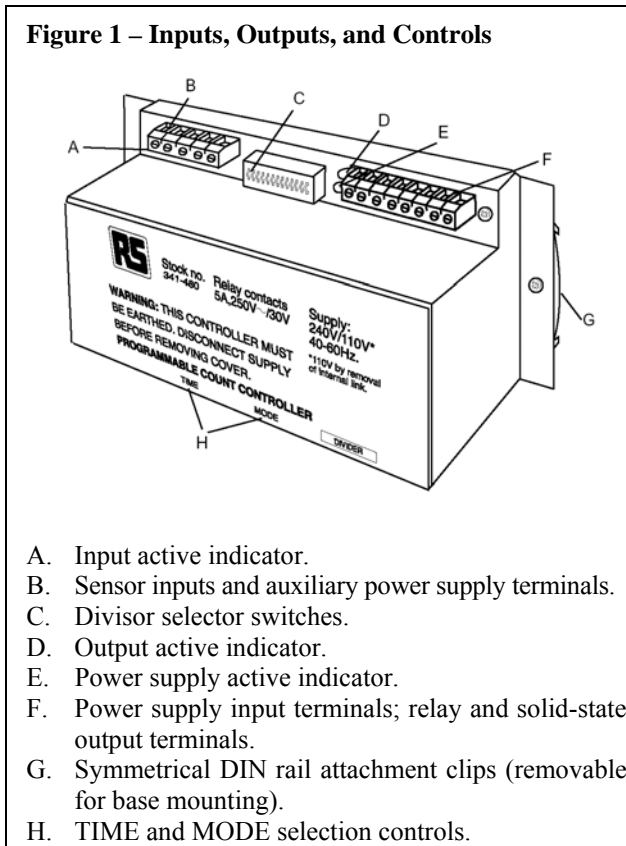

SETTING UP

The MV1 has internal jumpers which may be cut or repositioned to select supply voltage, relay options and input/output pulse rates. Please read all relevant sections prior to installation. Some or all of the jumpers may need to be configured to suit the application.

AC CONNECTION

Terminals 11, 12, and 13 are the L, N, and E respectively for the power mains. The MV1 is supplied, as standard, for operation on 230Vac mains. Operation at 115Vac is selectable through the positioning of internal soldered jumpers. Note: This operation requires soldering and should be performed by persons competent in soldering technique.

Proceed as follows to convert from 230 Vac operation to 115 Vac operation:

- Remove cover and four PCB retaining screws.
- Lift PCB clear from the base plate and invert it to reveal underside selection pins 1 – 5 (see Fig. 2).
- Change links as follows:
For 240V Supply — Jumper 1 to 2 (as supplied).
For 110V Supply — Remove Jumper 1 to 2; Jump 1 to 5; Jump 3 to 4 (Use 22 awg tinned copper wire).
- If no further configuration is required, then reassemble.
- Remove reference to 240V on product label.

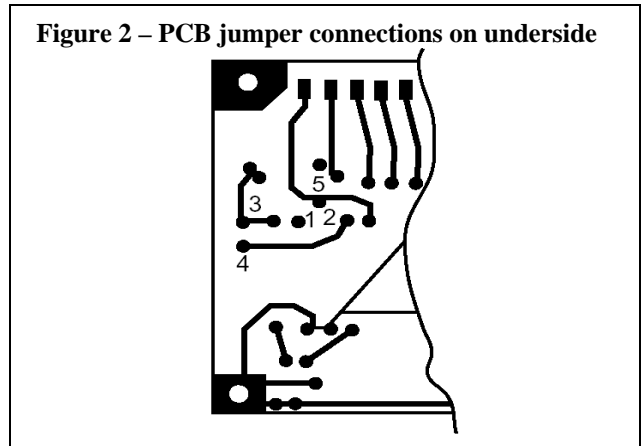

CONFIGURATION JUMPERS

RLY cut to disable internal relay.

IP cut to select 5kHz input pulse operation.

OPI cut to select 0.25ms minimum output pulse operation.

Note: Jumper locations are shown in bold outline in Figure 3.

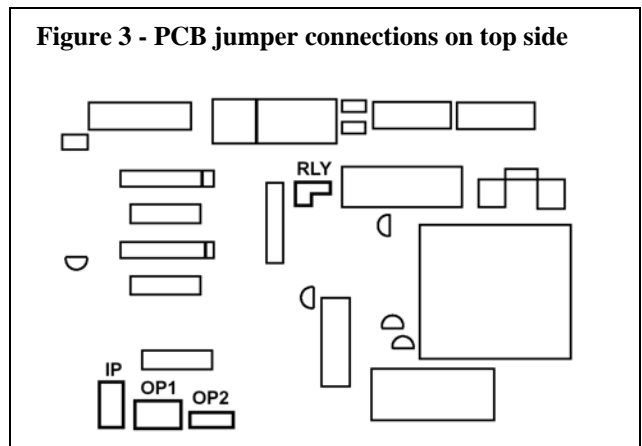

SENSOR CONNECTION

The MV1 can provide dc power for many of the solid-state sensors typically used in industrial application. Either NPN or PNP sensors may be connected. The table below identifies the functions of the sensor inputs and auxiliary power supply terminals:

Terminal	Function	Limit
1	0 V common	Sensor common; chassis
2	PNP Sensor input	Lo, sensor off Hi, sensor on, 4ma sink
3	NPN Sensor input	Hi, sensor off Lo, sensor on, 5ma source
4	12Vdc reg supply	25ma regulated supply
5	20Vdc unreg supply	30ma typ, see table below

The total current available from the 20Vdc unregulated supply is dependant on the unit configuration. Refer to the following table:

Configuration/application	Max current - 20Vdc supply
25mA, 12V load; internal relay connected	30mA
25mA, 12V load; internal relay disconnected	80mA
No 12V load; internal relay connected	55mA
No 12V load; internal relay disconnected	105mA

Note: The unregulated voltage may vary between 23V and 16V depending on the total load on both the regulated and unregulated supplies.

TYPICAL SENSOR CONNECTIONS

The following diagrams show typical sensor connections to the MV1 Programmable Frequency Divider.

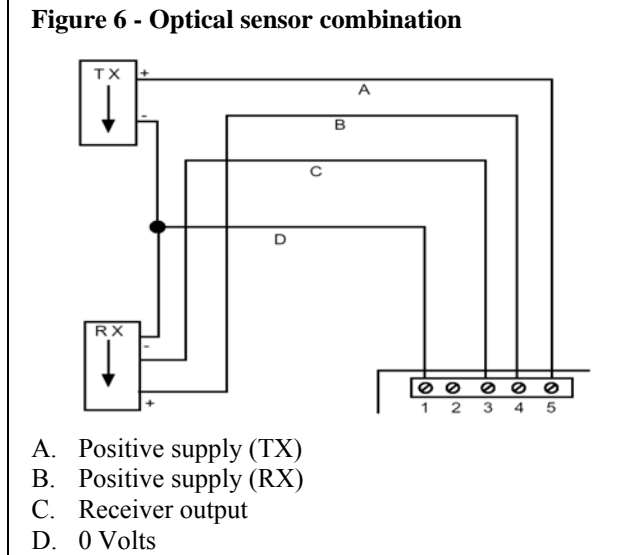
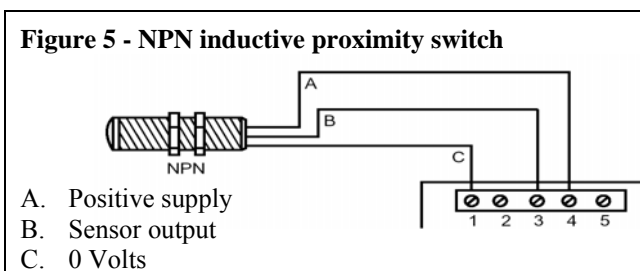
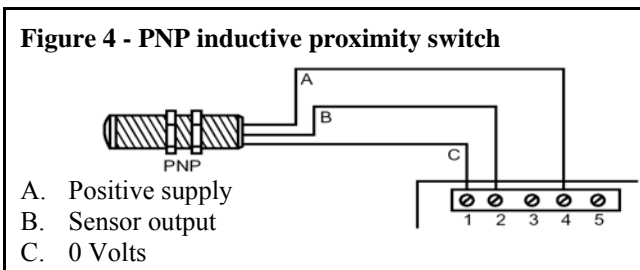

Note: It is recommended that the transmitter of an optical transmitter/receiver combination be powered from the unregulated supply (terminal 5) in order to reduce the current load on the regulated supply. This is particularly important when using long range sensors with high current transmitters.

SETTING "DIVIDE BY" SWITCHES

A 12-bit binary programming switch is located on the terminal side of the MV1 Divider. These switches are used to select the desired "divide by" value. To select a value move the combination of switches to the ON position which adds up to the desired value. For example: to divide the incoming pulse stream by 27, select switches $16 + 8 + 2 + 1 = 27$.

RELAY OUTPUT CONNECTION

A SPDT output relay capable of switching 5A at 30Vdc and 250Vac is provided. It is recommended that external surge protection be used if highly inductive loads are to be switched. Terminals 8, 9 and 10 are the NC, C and NO contacts respectively.

LCD DISPLAY COUNTER CONNECTION

The input to the majority of LCD display counters is negative edge triggered. The MV1 provides an output on terminal 6 which is compatible with this requirement. Figure 7 illustrates the connection of a typical battery powered LCD totalizing counter.

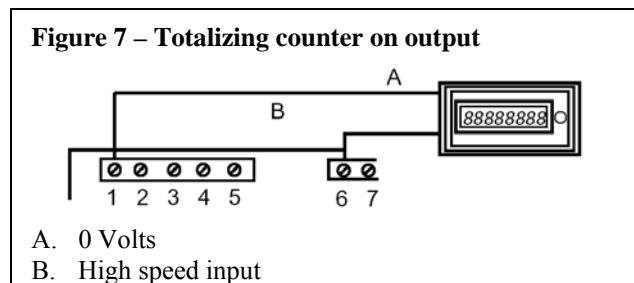

The MV1 also permits LCD counters to be connected to the inputs to monitor incoming pulses. Figure 8 illustrates the connection of a typical LCD totalizing counter. Note: In applications where PNP sensors are used, terminal 3 will still provide negative edge pulses compatible with the LCD counter input requirements.

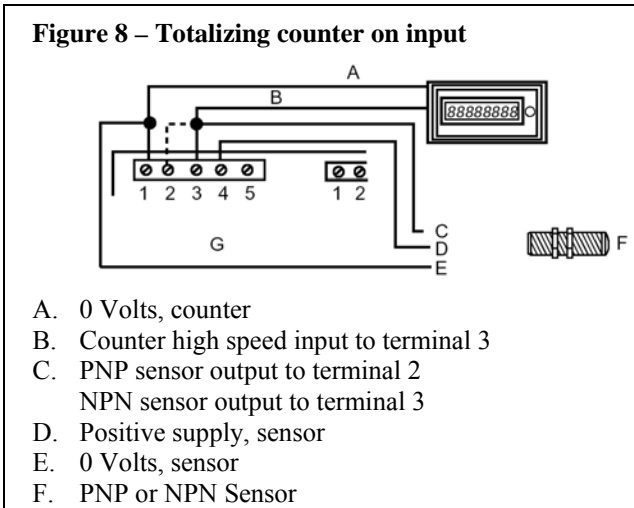

EXTERNAL RELAY

Some applications may require the use of an external relay, such as when multiple contacts are required. An alternative to using the contact of the internal relay and an additional power supply is to disable the internal relay and to connect an external relay as shown in Figure 9. When choosing the relay, consideration should be given to the coil power and pick-up characteristics and any other loads on the integral power supplies (see table under sensor connection). To disable the internal relay cut Jumper RLY (see Figure 3).

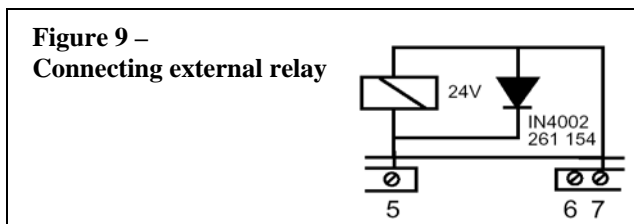

SOLID-STATE OUTPUT

In applications such as fast display counter driving or PLC input pre-scaling the internal relay must be disconnected by cutting Jumper RLY. An external load resistor (470 to 1k) must be connected as shown in Figure 10.

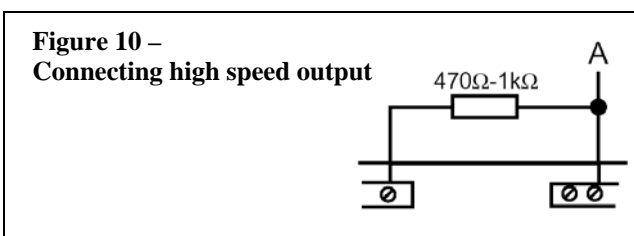

STATUS LED DISPLAYS

Three LEDs provide a visual indication of the condition of the input, output, and mains supply.

Green	IP	LED on when sensor is active
Red	OP	LED on when relay and/or solid-state output are active
Yellow	AC	LED on when power is applied.

PULSE COUNT DIVIDER

The MV1 produces a single output pulse after a preset number of input pulses have been detected. The divider ratio is selected using the SET switches as described on page 2. The duration of the output pulse may be adjusted to between 0.1 and 5.0 seconds by use of the potentiometer marked TIME (see Figure 1). Use a small screwdriver to make this adjustment. The unit will continue to sense input pulses during the output pulse duration so that the maximum output pulse width is limited by the input pulse rate and the SET divide ratio, unless inhibited as described below.

i.e. Maximum output pulse time =

$$\text{SET divide ratio} / \text{Input pulse frequency}$$

e.g. SET count of 40 and an input pulse frequency of 100 Hz limits the output pulse to a maximum of 0.4 seconds.

INHIBIT INPUT COUNT OPERATION

In some applications it may be necessary to inhibit sensing input pulses during the output pulse time. This may be achieved by linking terminals 6 and 3. In this configuration the output pulse duration is not limited by the input pulse rate and the SET divide ratio.

CHANGE OF STATE OPERATION

The output can be made to latch alternatively ON and OFF each time the SET number of input pulses has been detected. To select this mode the output control button marked MODE must be latched in.

HIGH SPEED INPUT PULSES

The maximum input pulse rate of the MV1 is set at 100Hz. This rate may be increased to 5kHz by cutting the internal Jumper IP (see figure 3). When operating in this mode it is essential that the sensor provides a bounce free signal. Note: At the maximum input pulse rate of 5kHz the minimum SET divide ratio is limited to 500 to allow for a 0.1 second output pulse.

HIGH SPEED OUTPUT PULSE

In applications where output pulses shorter than 0.1 seconds are required the internal relay must be disconnected and an external resistor load used (see notes under External Relay and Solid-state Output options). Internal Jumper OP1 must also be cut. Following these modifications the output pulse time period can now be varied between 0.25ms to 12ms using the TIME

potentiometer. Note: At the maximum input pulse rate of 5kHz the minimum SET divide ratio is limited to 2 to allow for a 0.25ms output pulse. Similarly, the minimum SET divide ratio is limited to 60 to allow for a 12ms output pulse.

MULTIPLE UNIT CONNECTION

The MV1 programmable pulse frequency divider has been designed to be used singularly or in combination to realize cost effective solutions to many industrial control tasks.

SERIAL CONNECTION

Examples of applications where it may be necessary to drive one divider unit from another are:

- Divider A provides input pulses to divider B to achieve batch counts greater than 4095 (up to 16.77 million).
- Divider, used in batch control application, providing an input to a multiplier and totalizing counter.

The wiring diagram in Figure 11 shows an example of serial connection. Unit A's output (terminal 6) is used as an input to Unit B's input (terminal 3).

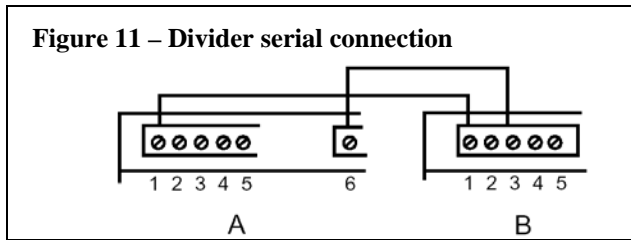

PARALLEL CONNECTION

Figures 12 and 13 show examples of parallel connection of multiple units driven from a single NPN or PNP sensor. The sensor can be powered from a single unit. The maximum number of units which can be driven by an NPN sensor is limited by the current sinking capability of the sensor since each controller contributes 5.5mA into the sensor (up to 18 units allowed for a 100mA capable sensor). The maximum number of units that can be driven by a PNP sensor (as illustrated in Figure 13) is ten.

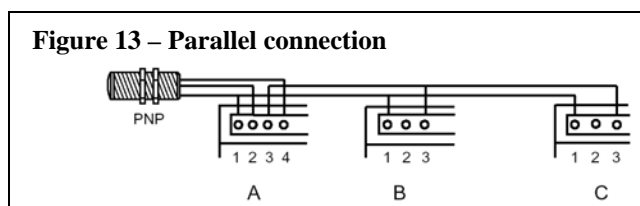
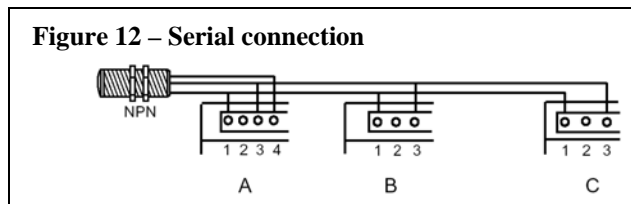

TECHNICAL SPECIFICATION

Mains Supply

Standard	230 Vac
By internal jumper change	115 Vac
Frequency	45-60 Hz
Phase	1 phase
Power consumption	6 Watts max.

Internal Power Supply

Regulated supply	12 Vdc at 25 ma max.
Unregulated supply	24 Vdc at 30 ma max.

Sensor Inputs

Input off	
NPN (sinking type)	12 V
PNP (sourcing type)	0 V
Input on	
NPN (sinking type)	0.2 V, 5.5 ma typ.
PNP (sourcing type)	12 V, 4.0 ma typ.

Relay Output

Relay contacts	SPDT, 5 A, 250 Vac, 30 Vdc
----------------------	----------------------------

Solid-state Outputs

Output off	
Internal relay connected	20 V
Internal relay disconnected	30 V max.
Output on	
Internal relay connected	5 ma sink
Internal relay disconnected	60 ma sink

Physical

Dimensions (inch)	6.3 x 3.45 x 1.9
Dimensions (mm)	160 x 88 x 48
Weight	20 ounces (580 grams)
Wire terminations	14 awg max.
Mounting	DIN rail, 35 mm
Optional	clips removable for base mounting
Operating Temp	-20°C to 65°C (5°F to 150°F)

Contact Information

Barrett Engineering
 606 L Street
 Fortuna, CA 95540
 Tel 707.725.9898
 Fax 707.72539899
 Web www.barretteng.com

Barrett Engineering shall not be liable for any liability or loss of any nature, howsoever caused and whether or not due to Barrett Engineering's negligence, which may result from the use of any information provided in Barrett Engineering literature whether provided in print or other media.